

High-Performance external gear pump AZPN

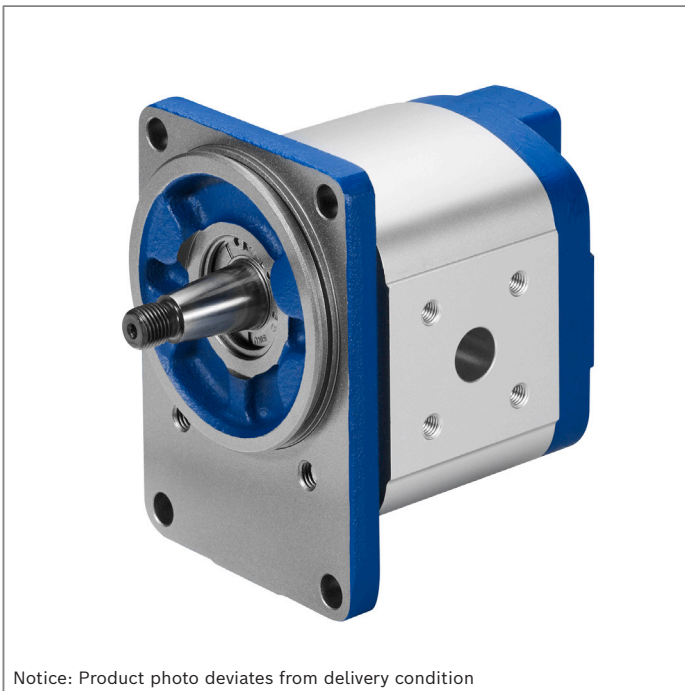

Notice: Product photo deviates from delivery condition

- ▶ Platform N
- ▶ Fixed displacement
- ▶ Nominal size 20 to 36
- ▶ Continuous pressure up to 250 bar
- ▶ Intermittent pressure up to 280 bar

Features

- ▶ Consistently high quality based on large-volume production
- ▶ Long service life
- ▶ Slide bearings for high loading
- ▶ Drive shafts according to ISO or SAE and customer-specific solutions
- ▶ Port connections: Connection flanges or screw-in threads
- ▶ Combinations of several pumps possible

Contents

Product description	2
Type code	4
Technical data	8
Hydraulic fluid	10
Drive	11
Maximum transferable drive torques	12
Multiple gear pumps	13
Flow characteristic curves	14
Power diagrams	14
Noise charts	16
Drive shafts	17
Front covers	18
Port connections	19
Dimensions – Preferred program	20
Project planning information	31
Information	32
Accessories	33

Product description

General information

It is the central task of external gear pumps to convert mechanical energy (torque and speed) into hydraulic energy (flow and pressure). To reduce heat losses, Rexroth's external gear units offer very high efficiencies. They are realized by pressure-dependent gap sealing and highly precise production technology.

Rexroth external gear pumps are built in four frame sizes: Platform B, F, N and G. Within each platform different sizes can be realized by different gear widths. The pumps are available in the versions Standard, High-Performance, SILENCE und SILENCE PLUS. Further configuration variants are given by different flanges, ports, shafts, valve arrangements and multiple pump combinations.

Pumping principle

Due to the teeth moving apart during the rotation from the tooth mesh, the gear chambers become clear. The resulting negative pressure as well as the atmospheric pressure on the hydraulic fluid level in the reservoir cause hydraulic fluid to flow from the reservoir to the pump. This hydraulic fluid fills the gear chambers and is transported in them in the direction of the arrow (see sectional drawing) along the housing from the suction side to the pressure side. The teeth mesh again then, force the hydraulic fluid out of the gear chambers and prevent it from flowing back to the suction chamber.

Construction

The external gear pump consists essentially of a pair of gear wheels supported in bearing bushings and the housing with a front cover and a rear cover.

The drive shaft protrudes from the front cover where it is usually sealed by the shaft seal. The bearing forces are absorbed by slide bearings. These bearings were designed for high pressures and have excellent emergency running properties, especially at low rotational speeds.

The gear wheels have 12 teeth. This keeps both flow pulsation and noise emission to a minimum. The sealing of the pressure chambers is achieved by forces depending on the working pressure. This ensures optimum efficiency.

The working pressure generated in the gear chambers is transferred to the outside of the bearing bushings in specifically designed pressure fields in such a way that they are pressed against the gears and seal them up. The pressurized compression areas are limited by special seals. The seal in the area between the gear teeth and the housing is ensured by the smallest of gaps that are set depending on the pressure between the gear teeth and housing.

▼ Axial and radial sealing of gear chambers

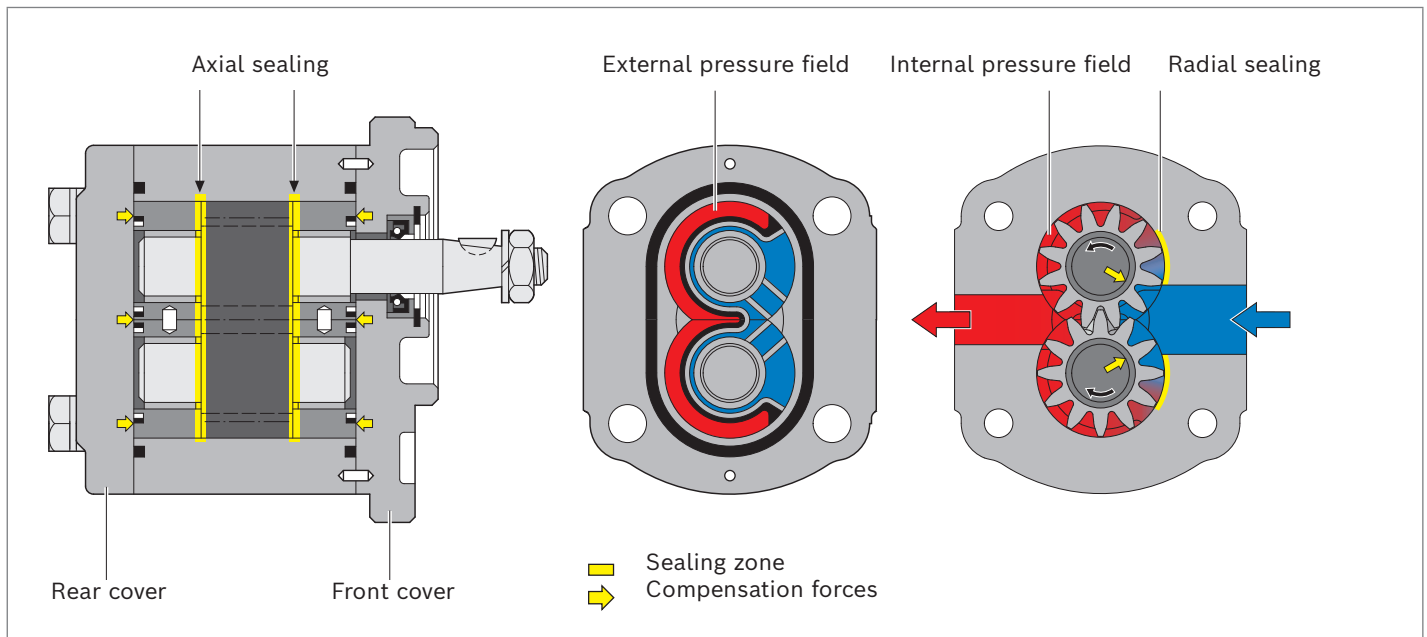

▼ Pumping principle of High Performance pump

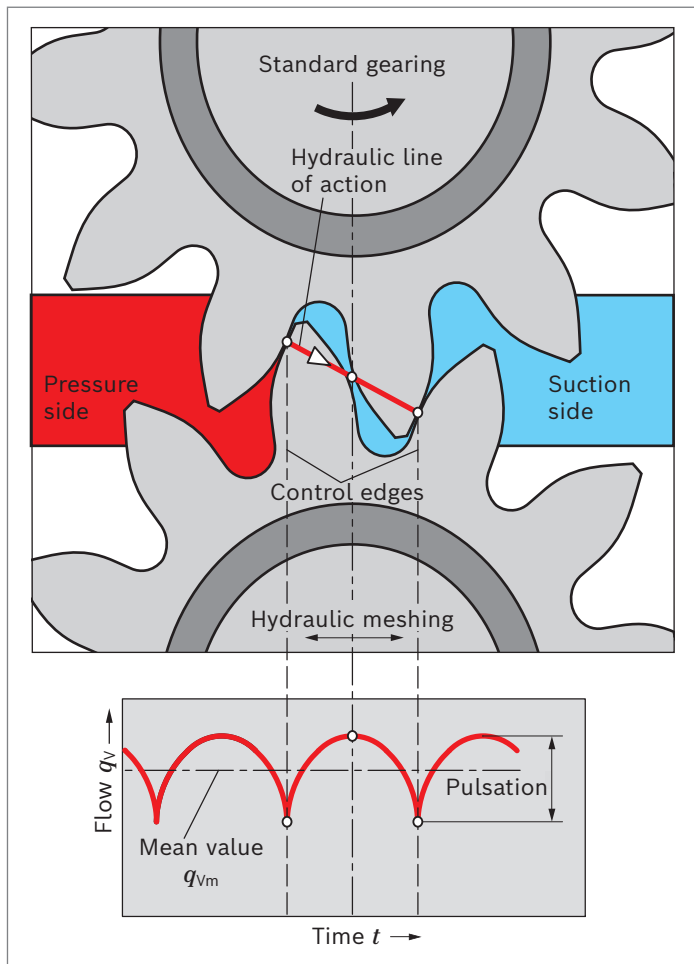

▼ Principle design of external gear pump

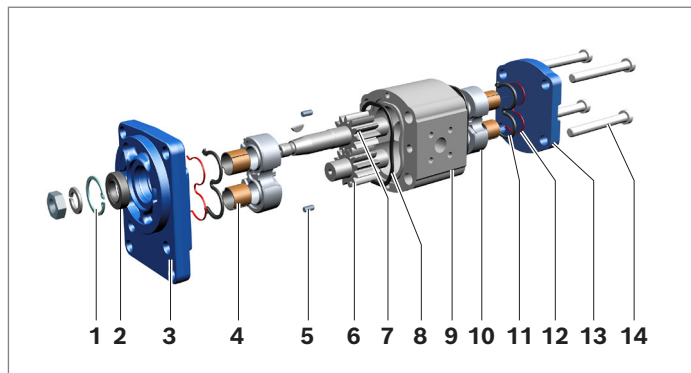

- | | |
|------------------|-----------------------|
| 1 Retaining ring | 8 Housing seal ring |
| 2 Shaft seal | 9 Pump housing |
| 3 Front cover | 10 Bearing bushing |
| 4 Slide bearings | 11 Axial field seal |
| 5 Centering pin | 12 Supporting element |
| 6 Gear wheel | 13 Rear cover |
| 7 Drive shaft | 14 Torx screws |

Type code

Type code single pump

01	02	03		04	05		06	07	08	09	10	11	12		13
AZ	P	N	-			-								-	

Product

01	External gear unit	AZ
----	--------------------	-----------

Function

02	Pump	P
----	------	----------

Model

03	High Performance, platform N (20 ... 36 cm ³ /rev)	N
----	---	----------

Series

04	Housing width 92 mm	1
	Housing width 110 mm	2

Version

05	Phosphated, high precision cover fixation	1
	Zinc plated, high precision cover fixation ¹⁾	2

Nominal size (NG)

06	Geometric displacement V_g [cm ³ /rev], see „Technical data“	020	022	025	028	032	036
----	---	------------	------------	------------	------------	------------	------------

Direction of rotation

07	Viewed on drive shaft	clockwise	R
		counter-clockwise	L

Drive shaft

Typical front cover

08	Tapered keyed shaft	1 : 5	B	C
	Tang drive		M	N
	Splined shaft	SAE J744 22-4 13T	C	D
		SAE J744 19-4 11T	C	P
		SAE J744 16-4 9T	R	R
	Parallel keyed shaft	SAE J744 16-1 (short version)	R,C	Q

Front cover

09	Rectangular flange	spigot dia. 100 mm		B
	2-bolt flange	spigot dia. 82.55 mm	SAE J744 82-2 (A)	R
		spigot dia. 101.6 mm	SAE J744 101-2 (B)	C
	2-bolt mounting	spigot dia. 52 mm	with O-ring	M

Port connection

10	SAE flange connection acc. to ISO 6162-1 with metric thread		07
	SAE flange connection acc. to ISO 6162-1 with UNC thread		15
	Square flange (German version)		20
	UN-thread acc. to ISO 11926-1/ASME B 1.1, O-ring		12

1) Corrosion-protected version, details see “Technical data“

01	02	03		04	05		06	07	08	09	10	11	12		13
AZ	P	N	-			-								-	

Sealing material

11	NBR (nitrile rubber)	M
	FKM (fluorocarbon rubber)	P
	NBR, shaft seal in FKM	K

Rear cover

12	Axial pressure and suction port	A
	Standard (cast iron)	B

Non standard version

13	Special version ¹⁾ (characteristics not covered by type code)	SXXXX
----	--	--------------

Notice

- ▶ Not all of the variants according to the type code are possible.
- ▶ Please select the desired pump with the help of the selection table (preferred types) or after consultation with Bosch Rexroth.
- ▶ Special options are available on request.

¹⁾ For more information about special version, please contact us.

Type code multiple pump

01	02	03	04	05	06	07	08	09	10	11	12	13
AZ	P		-			-						

Product

01	External gear unit	AZ
----	--------------------	-----------

Function

02	Pump	P
----	------	----------

Model¹⁾

03	Standard-Performance	4.0 ... 25 cm ³ /rev	Data sheet 10090	W
	High-Performance	1.0 ... 7.1 cm ³ /rev	Data sheet 10088	B
		4.0 ... 28 cm ³ /rev	Data sheet 10089	F
		20.0 ... 36 cm ³ /rev	Data sheet 10091	N
		SILENCE	4.0 ... 28 cm ³ /rev	Data sheet 10095
		20.0 ... 36 cm ³ /rev	Data sheet 10092	T
	SILENCE PLUS	12.0 ... 28 cm ³ /rev	Data sheet 10094	J

Series (according to data sheet of pump stage 1)

04	Housing width 92 mm	1
	Housing width 110 mm	2

Version (according to data sheet of pump stage 1)

05	Phosphated, pinned	1
	Corrosion-protected, pinned	2

Nominal size (NG)²⁾

06	In accordance with data sheet for the individual series	
----	---	--

Direction of rotation

07	Viewed on drive shaft	clockwise	R
		counter-clockwise	L

Drive shaft (according to pump stage1)

08	In accordance with data sheet of pump stage 1	
----	---	--

Front cover (according to pump stage1)

09	In accordance with data sheet of pump stage 1	
----	---	--

Port connection (per pump stage)³⁾

10	In accordance with data sheet for the individual series	
----	---	--

Sealing material

11	NBR (nitrile rubber)	M
	FKM (fluorocarbon rubber)	P
	NBR (nitrile rubber), shaft seal in FKM (fluorocarbon rubber)	K

Rear cover (according to last pump stage)

12	In accordance with data sheet of the last pump stage	
----	--	--

Non standard version

13	Special version (characteristics not covered by type code)	SXXXX
----	--	--------------

1) A letter is to be selected for each pump stage, e.g. triple pump AZPJ + AZPJ + AZPB: AZPJ**JB**

2) A numerical value is to be selected for each pump stage, e.g. triple pump **028/016/2.0**

3) A numerical value is to be selected for each pump stage, e.g. triple pump **202020**

Notice

- ▶ Not all of the variants according to the type code are possible.
- ▶ Please select the desired pump with the help of the selection table (preferred types) or after consultation with Bosch Rexroth.
- ▶ Special options are available on request.

Example triple pump:

AZPN...020... + AZPN...025... + AZPF...016...

01	02	03		04	05		06	07	08	09	10	11	12
AZ	P	NNF	-	1	2	-	020/025/016	R	D	C	20202020	K	B

Technical data

Operating conditions AZPN series 1x

Nominal size			20	22	25	28	32	36	
Displacement geometric, per revolution	V_g	cm ³	20	22.5	25	28	32	36	
Pressure at suction port S ¹⁾	absolute	p_e	0.7 ... 3						
Maximum continuous pressure		p_1	230	230	230	210	180	160	
Maximum intermittent pressure ²⁾		p_2	250	250	250	230	200	180	
Maximum pressure peaks		p_3	270	270	270	250	220	200	
Minimum rotational speed at	$v = 12 \text{ mm}^2/\text{s}$	$p \leq 100 \text{ bar}$	n_{\min}	rpm	500	500	500	500	500
		$p = 100 \dots 180 \text{ bar}$	n_{\min}	rpm	600	600	600	600	600
		$p = 180 \text{ bar} \dots p_2$	n_{\min}	rpm	800	800	800	800	800
Minimum rotational speed at	$v = 25 \text{ mm}^2/\text{s}$	at p_2	n_{\min}	rpm	500	500	500	500	500
		Maximum rotational speed	at p_2	n_{\max}	rpm	3000	3000	3000	2800

Operating conditions AZPN series 2x

Nominal size			20	22	25	28	32	36	
Displacement geometric, per revolution	V_g	cm ³	20	22.5	25	28	32	36	
Pressure at suction port S ¹⁾	absolute	p_e	0.7 ... 3						
Maximum continuous pressure		p_1	250	250	250	230	210	180	
Maximum intermittent pressure ²⁾		p_2	280	280	280	260	240	210	
Maximum pressure peaks		p_3	300	300	300	280	260	230	
Minimum rotational speed at	$v = 12 \text{ mm}^2/\text{s}$	$p \leq 100 \text{ bar}$	n_{\min}	rpm	500	500	500	500	500
		$p = 100 \dots 180 \text{ bar}$	n_{\min}	rpm	600	600	600	600	600
		$p = 180 \text{ bar} \dots p_2$	n_{\min}	rpm	800	800	800	800	800
Minimum rotational speed at	$v = 25 \text{ mm}^2/\text{s}$	at p_2	n_{\min}	rpm	500	500	500	500	500
		Maximum rotational speed	at p_2	n_{\max}	rpm	3000	3000	3000	2800

Rotary stiffness of drive shaft

Drive shaft		C	N	D	P	Q	R	
Rotary stiffness	c	Nm/rad	489	626	626	468	489	293

General technical data

Weight	m	kg	See chapter "Dimensions"
Installation position			No restrictions
Mounting type			Flange or through-bolting with spigot
Port connections			See chapter "Port connections" on page 19
Direction of rotation, viewed on drive shaft			Clockwise or counter-clockwise, the pump may only be driven in the direction indicated
Drive shaft loading			Axial and radial forces only after consultation
Ambient temperature range	t	°C	-30 ... +80 with NBR seals (NBR = nitrile rubber)
			-20 ... +110 with FKM seals (FKM = fluorocarbon rubber)

Corrosion protection

Version 1 (phosphated): Unit with low corrosion protection	The surface serves for protection against flash rust during transport or as priming for painting.		
Version 2 (galvanized, passivated): Unit with corrosion protection	Degree of corrosion and rust according to DIN EN ISO 9227	Test duration 96 h: no red rust	

- 1) In the case of tandem pumps, the suction-side pressure difference between the individual pump stages must not exceed 0.5 bar. 2) Limited service life with threaded ports (applicable for applications with $p_2 > 210 \text{ bar}$)

Notice

- ▶ Safety requirements pertaining to the whole systems are to be observed.
- ▶ Please contact us for applications with frequent load changes.

▼ **Pressure definition**

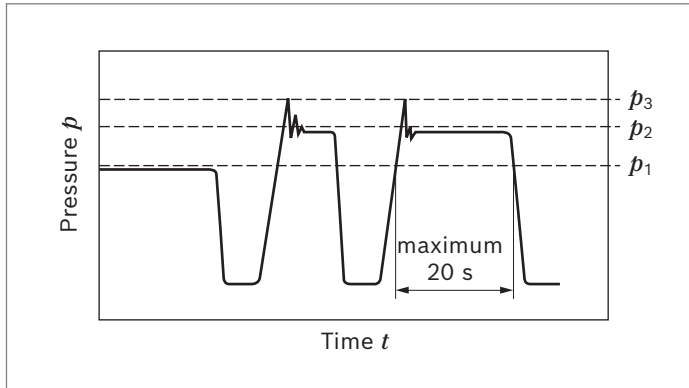

p_1 : Maximum continuous pressure
 p_2 : Maximum intermittent pressure
 p_3 : Maximum pressure peaks

Determining the operating characteristics

Flow	$q_v = \frac{V_g \times n \times \eta_v}{1000}$	[l/min]
Torque	$M = \frac{V_g \times \Delta p}{20 \times \pi \times \eta_{hm}}$	[Nm]
Power	$P = \frac{2 \pi \times M \times n}{60000} = \frac{q_v \times \Delta p}{600 \times \eta_t}$	[kW]

Key

- V_g Displacement per revolution [cm³]
- Δp Differential pressure [bar] ($\Delta p = p - p_e$)
- n Rotational speed [rpm]
- η_v Volumetric efficiency
- η_{hm} Hydraulic-mechanical efficiency
- η_t Total efficiency ($\eta_t = \eta_v \times \eta_{hm}$)

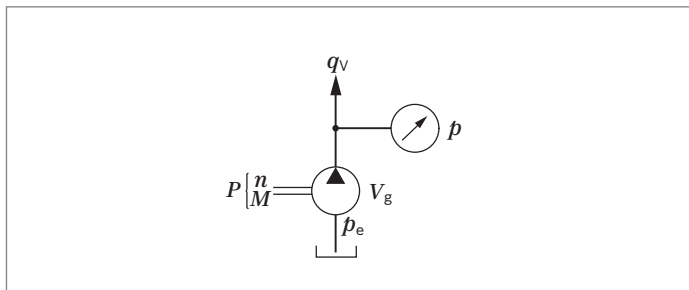

Notice

You can find diagrams for a rough calculation in chapter "Diagrams/Characteristic curves".

Direction of rotation

The dimensional drawings in the chapter Dimensions represent pumps for clockwise rotation. The position of the drive shaft and/or the position of suction and pressure port changes for counter-clockwise rotation.

▼ **Direction of rotation, viewed on drive shaft**

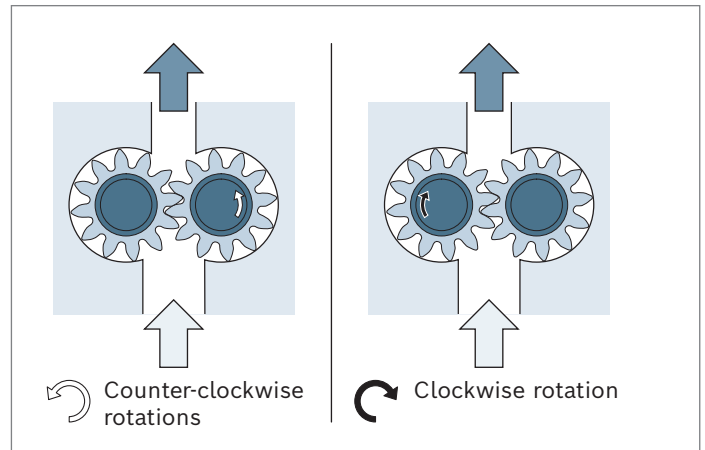

Hydraulic fluid

The external gear unit is designed for operation with HLP mineral oil according to DIN 51524, 1-3. Under higher load, however, Bosch Rexroth recommends at least HLP compliant with DIN 51524 Part 2.

See the following data sheet for application instructions and requirements for selecting hydraulic fluid, behavior during operation as well as disposal and environmental protection before you begin project planning:

- ▶ 90220: Hydraulic fluids based on mineral oils and related hydrocarbons

Other hydraulic fluids on request.

Selection of hydraulic fluid

Bosch Rexroth evaluates hydraulic fluids on the basis of the Fluid Rating according to the technical data sheet 90235.

Hydraulic fluids with positive evaluation in the Fluid Rating are provided in the following technical data sheet:

- ▶ 90245: Bosch Rexroth Fluid Rating List for Rexroth hydraulic components (pumps and motors)

Selection of hydraulic fluid shall make sure that the operating viscosity in the operating temperature range is within the optimum range (v_{opt} see “Selection diagram”)

Viscosity and temperature of hydraulic fluids

Viscosity range	
Permissible in continuous operation	$v = 12 \dots 800 \text{ mm}^2/\text{s}$
Recommended in continuous operation	$v_{opt} = 20 \dots 100 \text{ mm}^2/\text{s}$
Permissible for cold start	$v_{max} \leq 2000 \text{ mm}^2/\text{s}$
Temperature range	
With NBR seals (NBR = nitrile rubber)	$t = -30 \text{ °C} \dots +80 \text{ °C}$
With FKM seals (FKM = fluorocarbon rubber)	$t = -20 \text{ °C} \dots +110 \text{ °C}$

▼ Selection diagram

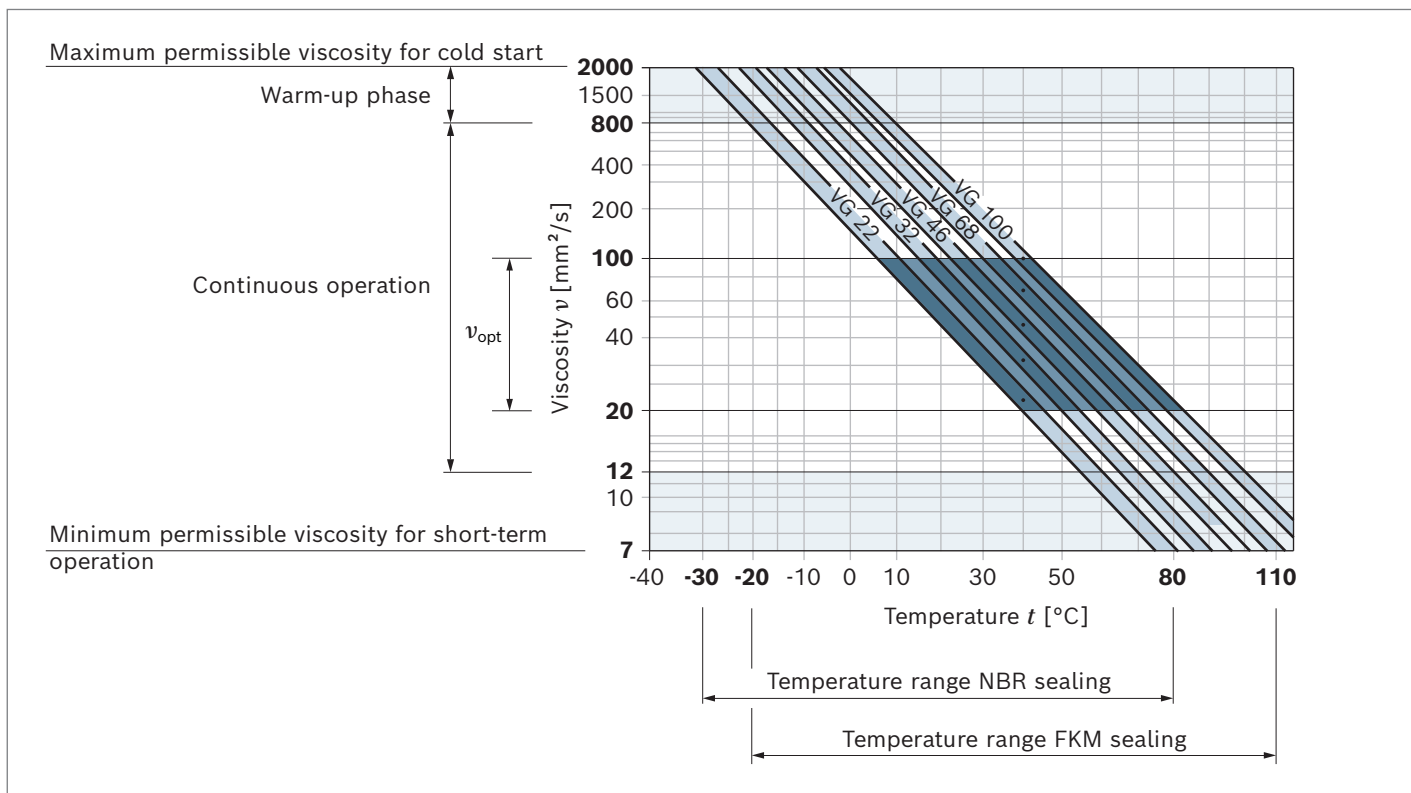

Observe the instructions for the filtration of the hydraulic fluid (see chapter “Project planning information”).

Drive

1. Elastic couplings

- ▶ The coupling must not transfer any radial and axial forces onto the pump.
- ▶ The radial runout deviation from the shaft to the spigot should not exceed 0.2 mm.
- ▶ Admissible shaft shifting see installation information of the coupling manufacturers.

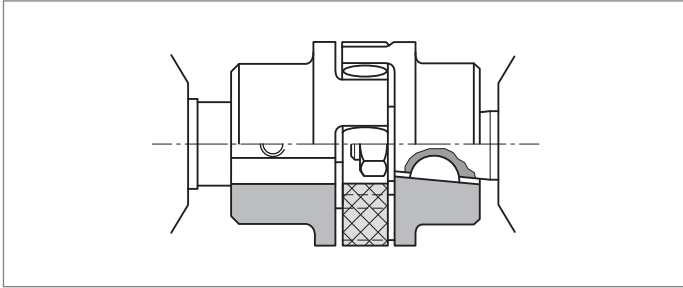

2. Coupling sleeve

- ▶ To be used on splined shaft profile according to DIN and SAE.
- ▶ Attention: No radial or axial forces are permitted on the pump drive shaft or coupling sleeve. The coupling sleeve must be free to move axially.
- ▶ The distance between the pump drive shaft and drive shaft on the customer side must be $3.5+1.5$ mm.
- ▶ Reserve installation space for the retaining ring.
- ▶ Oil-bath or oil-mist lubrication is required.

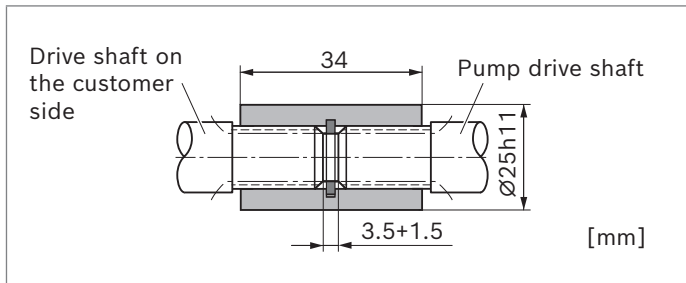

3. Tang drive coupling

- ▶ For attaching the pump directly to an electric motor or combustion engine, gearbox, etc.
- ▶ Pump drive shaft with special tang drive coupling and driver (3) (scope of delivery see offer drawing)
- ▶ No shaft seal
- ▶ Drive-side installation and sealing according to the following recommendations and dimensions
- ▶ Drive shaft on the customer side (1)
 - Case-hardened steel DIN EN 10084, e.g. 20MnCrS5 case-hardened 1.0 deep; HRA 83±2
 - Seal ring contact surface ground without rifling $R_t \leq 4 \mu\text{m}$
- ▶ Radial shaft seal ring on the customer side (2)
 - Provide with rubber cover (see DIN 3760, type AS, or double-lipped ring)
 - Provide installation edges with 15° chamfer or install shaft seal with protection sleeve

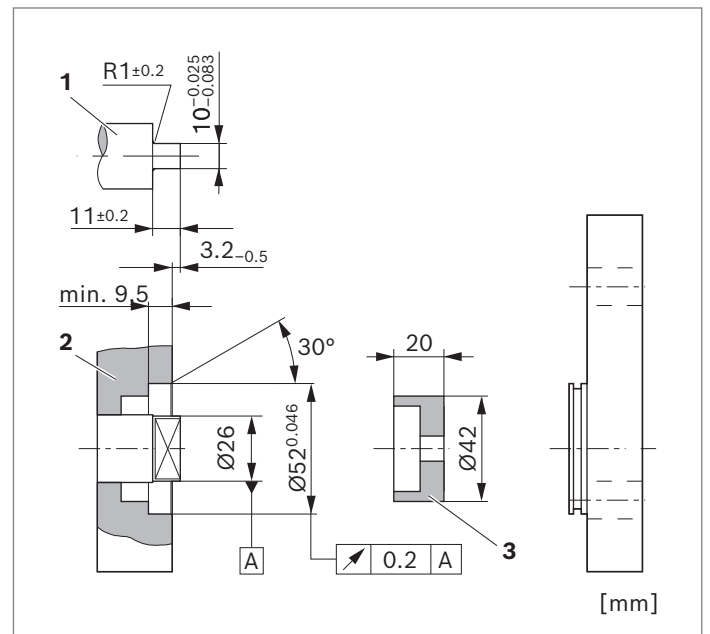

Maximum transferable drive torques

▼ Tapered keyed shaft

Drive shaft		M_{\max}	Nominal size	$p_{2 \max}$ Series 1x	$p_{2 \max}$ Series 2x
Code	Designation	Nm		bar	bar
C	1 : 5	200	20 ... 25	250	280
			28	230	260
			32	200	240
			36	180	210

▼ Splined shafts

Drive shaft		M_{\max}	Nominal size	$p_{2 \max}$ Series 1x	$p_{2 \max}$ Series 2x
Code	Designation	Nm		bar	bar
D	SAE J744 22-4 13T	320	20 ... 25	250	280
			28	230	260
			32	200	240
			36	180	210
P	SAE J744 19-4 11T	180	20 ... 25	250	280
			28	230	260
			32	200	240
			36	180	210
R	SAE J744 16-4 9T	110	20	250	270
			22	250	270
			25	240	250
			28	220	220
			32	190	190
			36	170	170

▼ Tang drive

Drive shaft		M_{\max}	Nominal size	$p_{2 \max}$ Series 1x	$p_{2 \max}$ Series 2x
Code	Designation	Nm		bar	bar
N	Tang drive	95	20	250	270
			22	240	240
			25	220	220
			28	190	190
			32	170	170
			36	150	150

▼ Parallel keyed shaft

Drive shaft		M_{\max}	Nominal size	$p_{2 \max}$ Series 1x	$p_{2 \max}$ Series 2x
Code	Designation	Nm		bar	bar
Q	SAE J744 16-1 (short version)	80	20	220	220
			22	200	200
			25	180	180
			28	160	160
			32	140	140
			36	120	120

Multiple gear pumps

Gear pumps are well-suited to multiple arrangements, whereby the drive shaft of the first pump stage is extended to a second and possibly third pump stage. The shaft of the individual pump sections are normally connected via a driver or via a splined coupling (reinforced through drive). The individual pump stages are usually hydraulically isolated and have separate suction ports. On request a common suction port or separated but hydraulically connected suction ports are available.

For the configuration of multiple pumps, Bosch Rexroth recommends arranging the pump stage with the largest displacement on the drive side.

Notice

Basically, the parameters of the single pumps apply, however certain restrictions need to be observed:

► **Maximum rotational speed:**

This is determined by the largest pump stage used.

► **Pressures:**

These are restricted by the maximum transmissible torques of the drive shaft, the through drive and the driver.

Addition of drive torques

Please note, that in multiple pump arrangements the drive torques of the individual pump stages will add up according to the following formula:

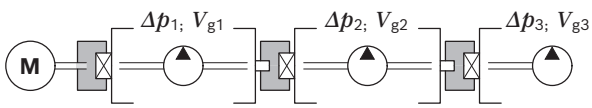

$$\frac{\Delta p_1 \times V_{g1} + \Delta p_2 \times V_{g2} + \Delta p_3 \times V_{g3}}{18 \times \pi} \leq M_{\max} \text{ 1)} \quad \begin{matrix} \Delta p \text{ [bar]} \\ V_g \text{ [cm}^3\text{]} \end{matrix}$$

This may result in pressure restrictions for the respective pump stages.

Standard through drive (tang drive coupling)

For Platform N (AZPN, AZPT) pumps, the driver for the next pump stage can support loads up to $M_{\max} = 95 \text{ Nm}$. This may result in pressure limitations for subsequent pump stages.

Subsequent pumps of a smaller series determine the maximum transmissible torque.

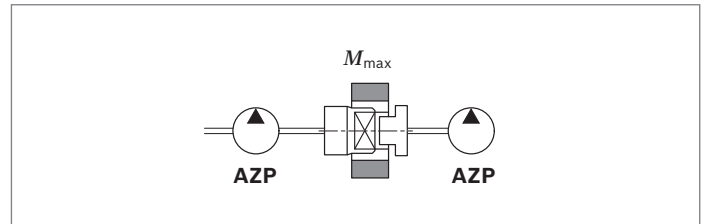

Following pump	M_{\max} [Nm]	
Platform N	AZPN-1x	95
	AZPN-2x	95
	AZPT	95
Platform F	AZPW	52
	AZPF-1x	65
	AZPF-2x	85
	AZPS-1x	65
	AZPS-2x	85
Platform B	AZPJ	65
	AZPB-3x	25

Reinforced through drive

Reinforced through drives (for up to $M_{\max} = 160 \text{ Nm}$) are available for applications with higher torques/torsional vibrations. Design available on request.

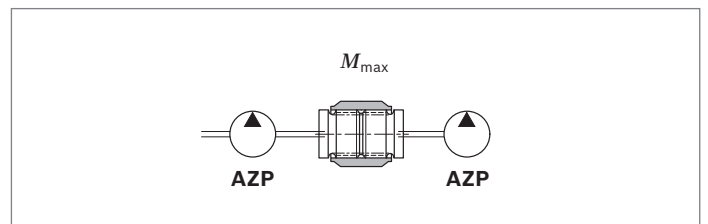

1) M_{\max} : see table above “Maximum transferable drive torques”

Flow characteristic curves

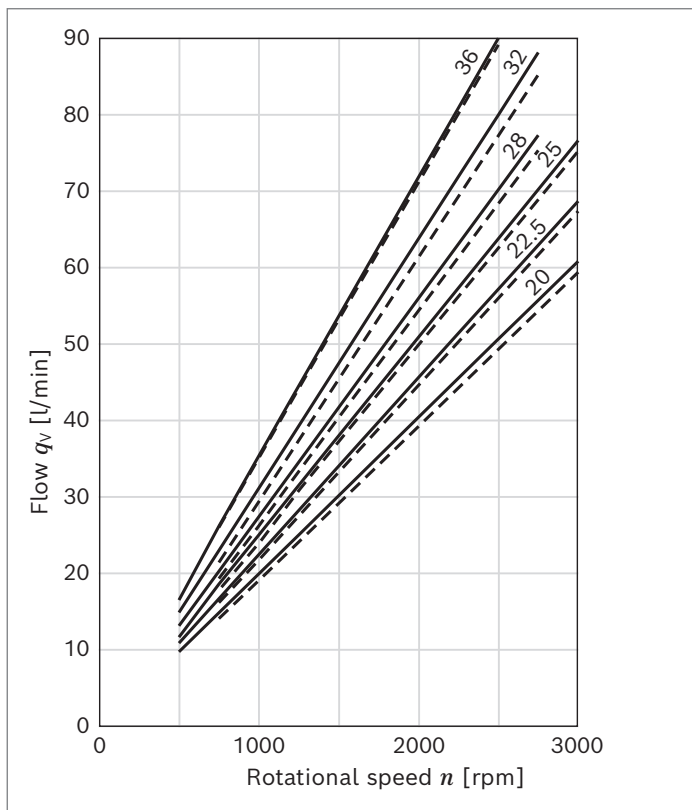

— $p = 20$ bar
 ··· $p_2 = \text{maximal intermittierend}$
 $q_v = f(n, V_g)$

Notice

Characteristic curves measured at $\nu = 32 \text{ mm}^2/\text{s}$ and $t = 50 \text{ }^\circ\text{C}$

Power diagrams

▼ Nominal size 20

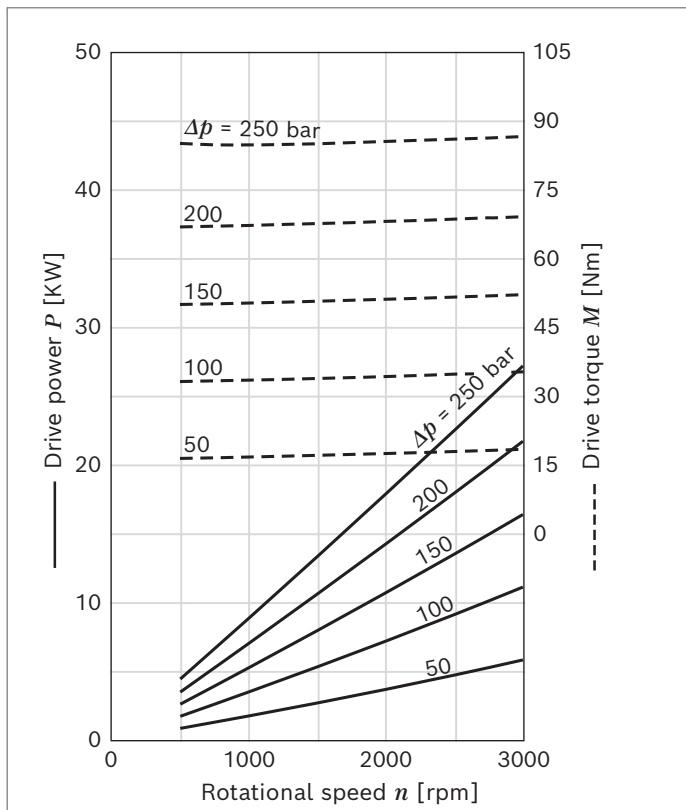

▼ Nominal size 22

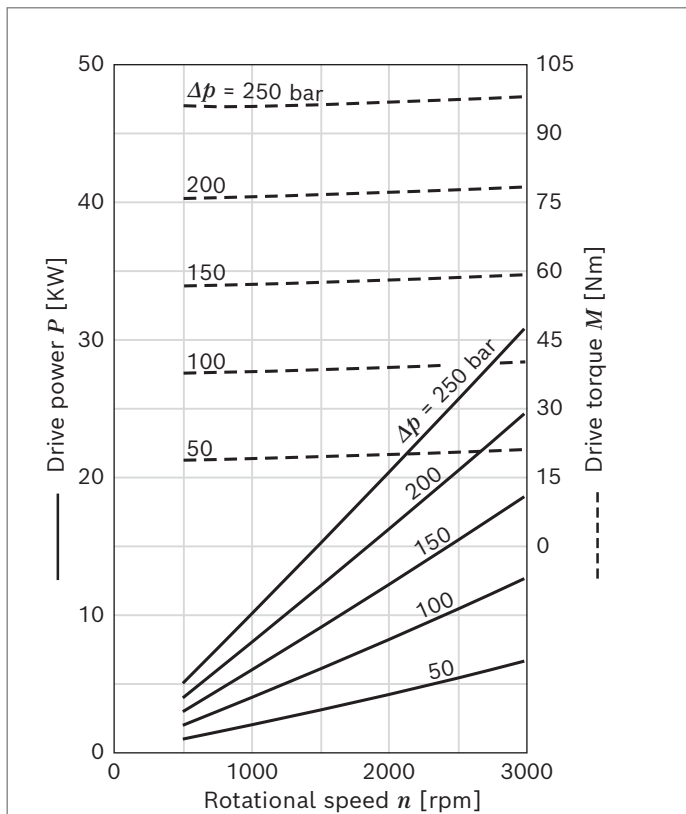

▼ **Nominal size 25**

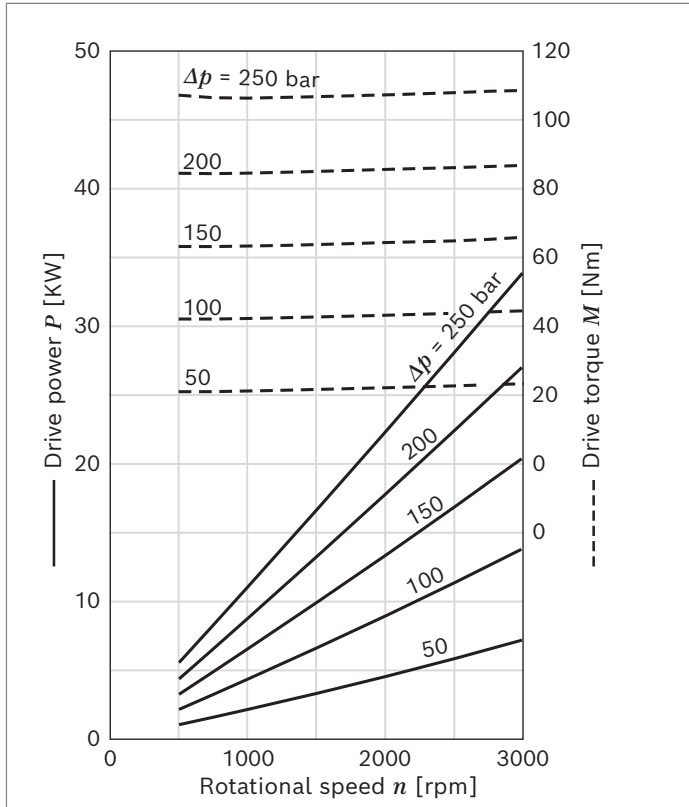

▼ **Nominal size 28**

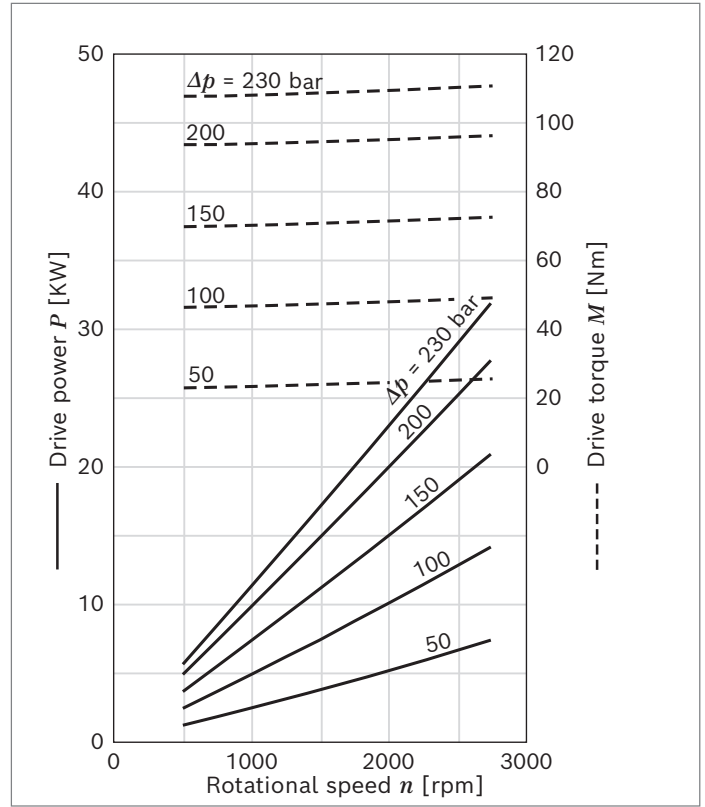

▼ **Nominal size 32**

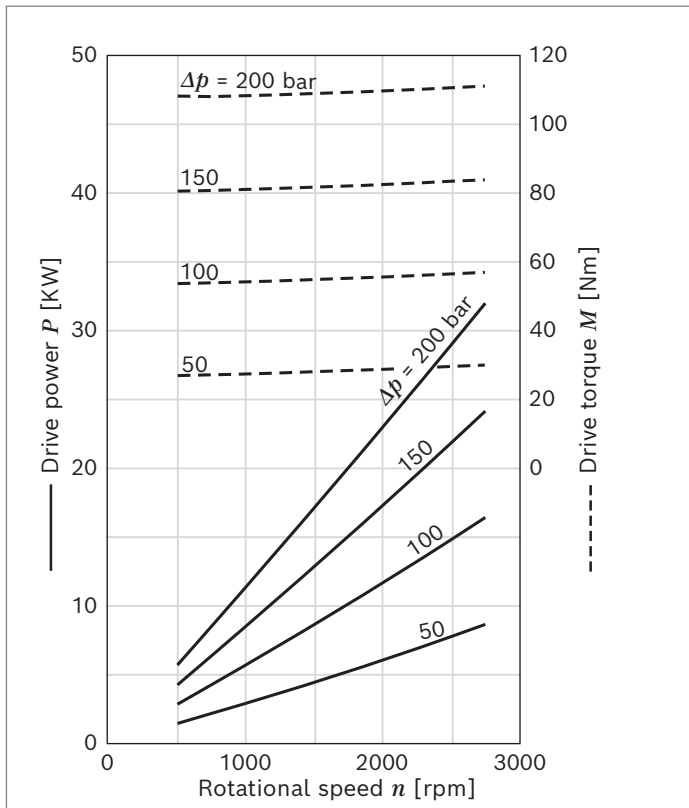

▼ **Nominal size 36**

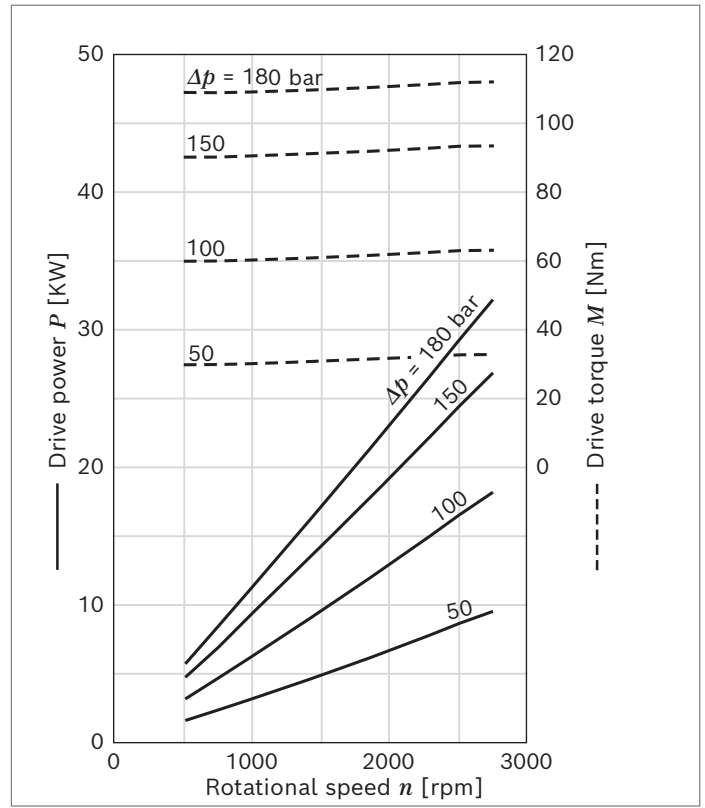

Noise charts

Noise levels dependent on the rotational speed, pressure range between 10 bar and pressure value p_2 (see chapter “Technical data”).

These are typical characteristic values for the respective size. They describe the airborne sound emitted solely by the pump.

Ambient influences (installation site, piping, other system components) were not taken into account.

The values refer to one individual pump.

Notice

- ▶ Characteristic curves measured at $v = 32 \text{ mm}^2/\text{s}$ and $t = 50 \text{ }^\circ\text{C}$.
- ▶ Sound pressure level calculated from noise measurements made in the low reflection measuring room according to DIN 45635, Part 26.
- ▶ Distance from measuring sensor to pump: 1 m.

▼ Nominal size 20

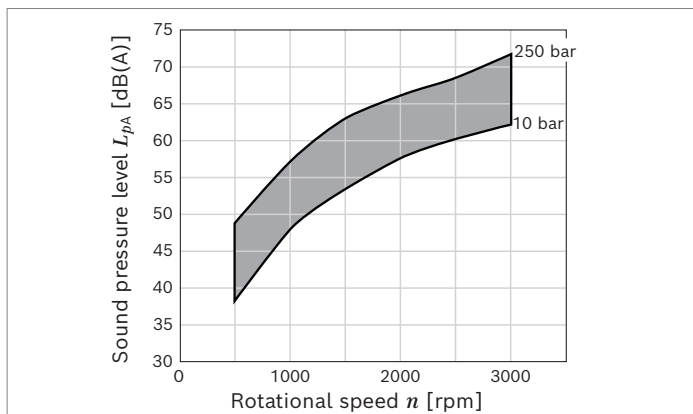

▼ Nominal size 22

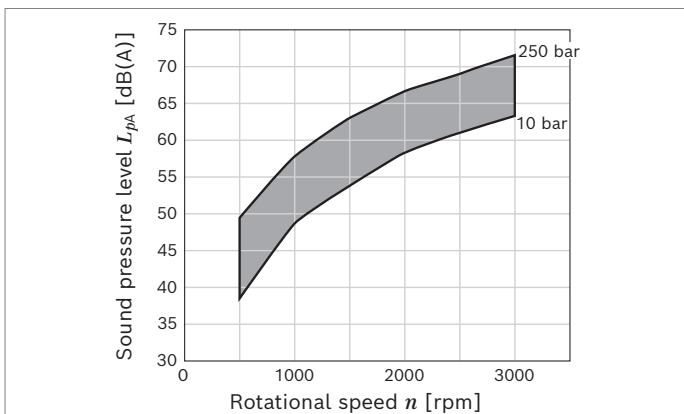

▼ Nominal size 25

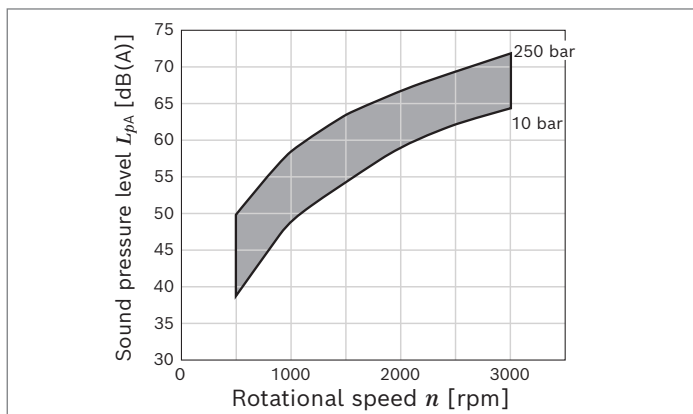

▼ Nominal size 28

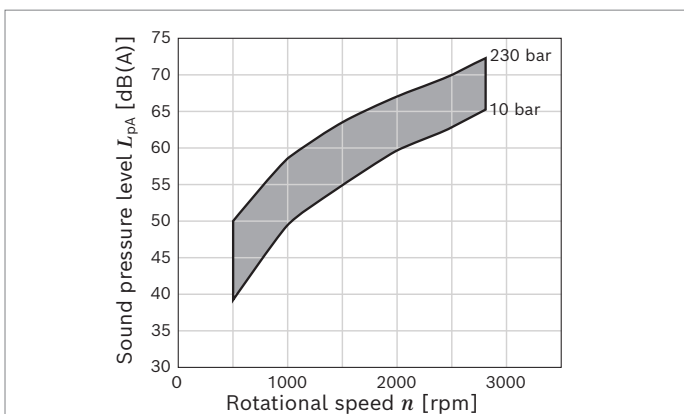

▼ Nominal size 32

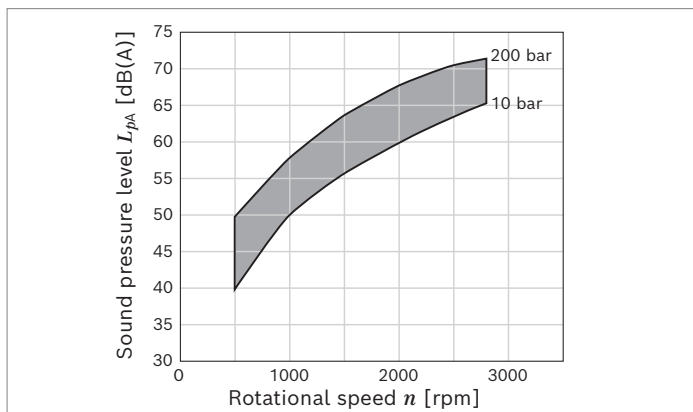

▼ Nominal size 36

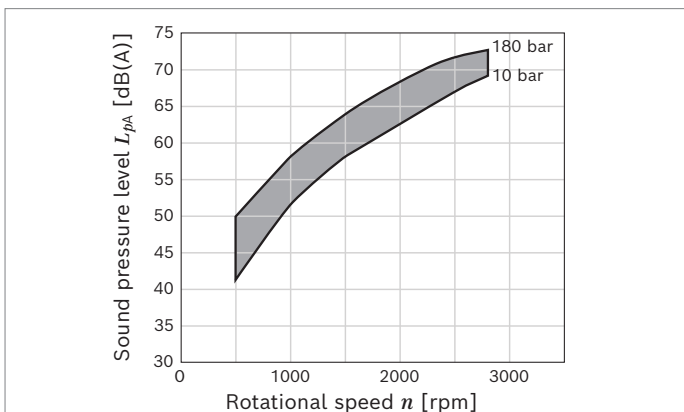

Drive shafts

▼ Tapered keyed shaft 1:5

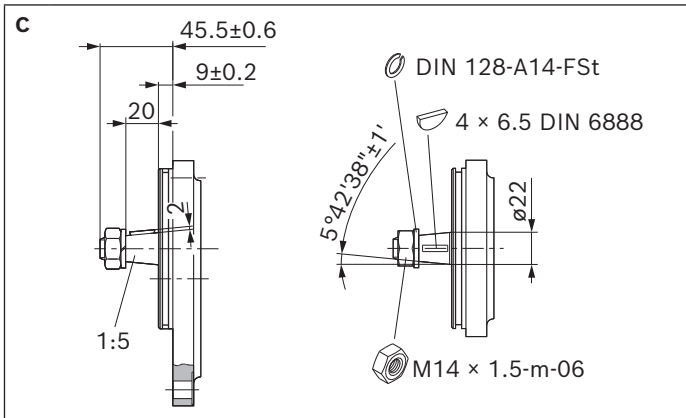

▼ Tang drive

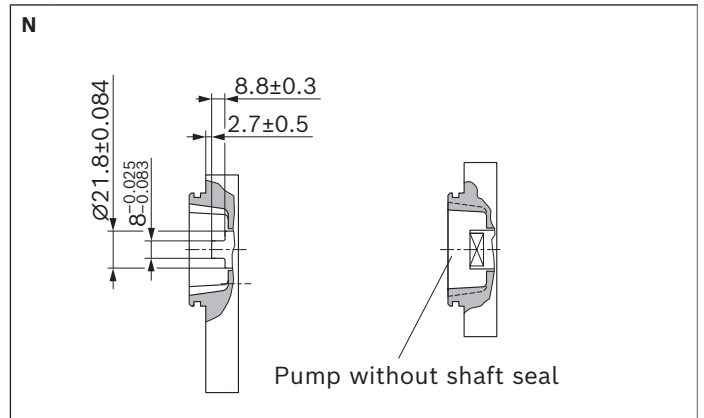

▼ Splined shaft SAE J744 22-4 13T

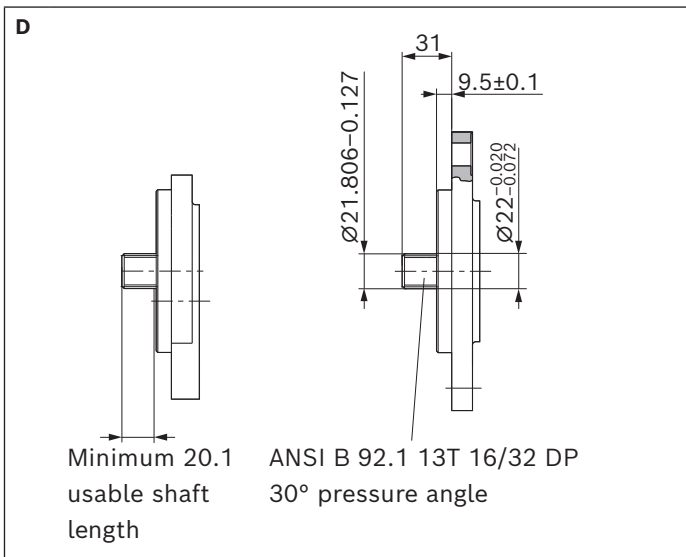

▼ Splined shaft SAE J744 19-4 11T

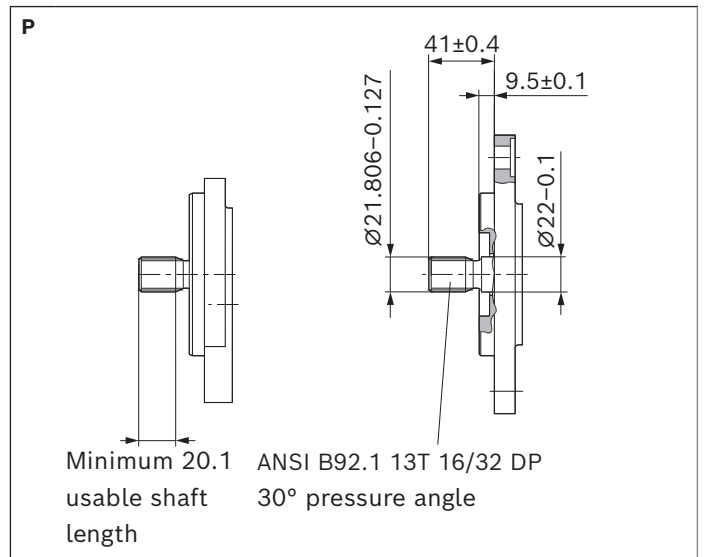

▼ Splined shaft SAE J744 16-4 9T

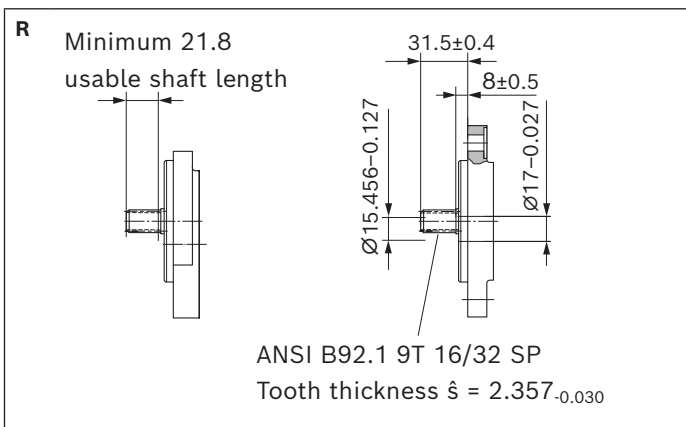

▼ Parallel keyed shaft SAE J744 16-1 (short version)

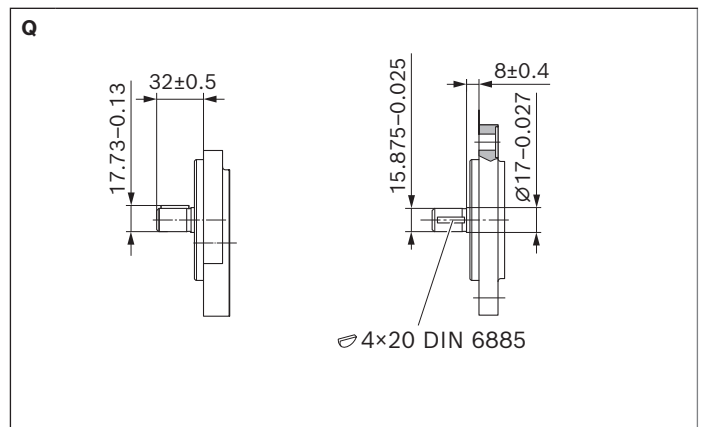

Front covers

▼ Rectangular flange spigot dia. 100 mm

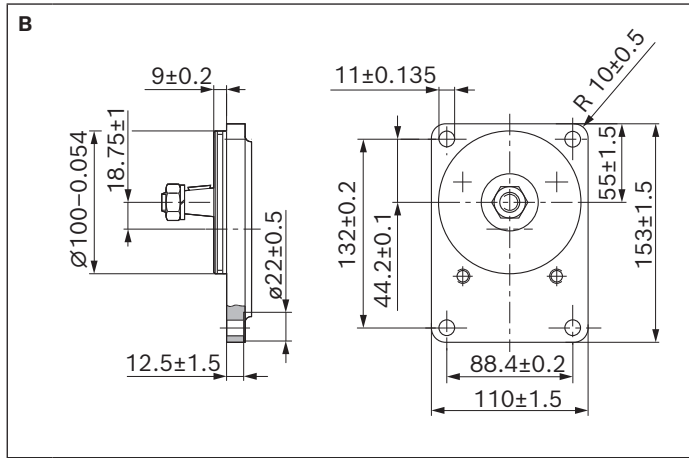

▼ 2-bolt flange SAE J744 82-2 (A) spigot dia. 82.55 mm

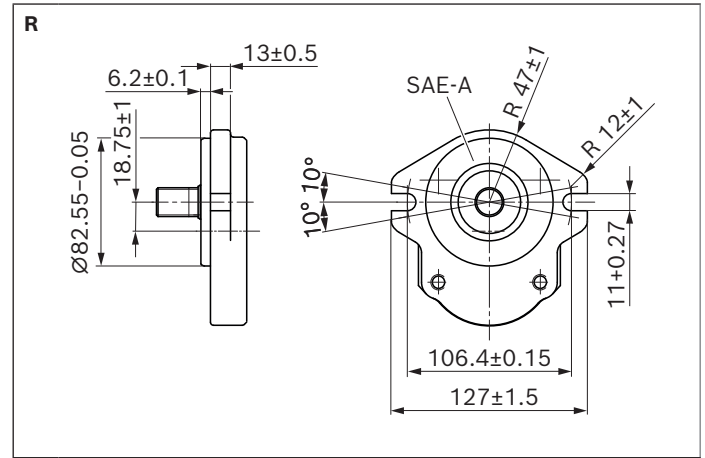

▼ 2-bolt flange SAE J744 101-2 (B) spigot dia. 101.6 mm

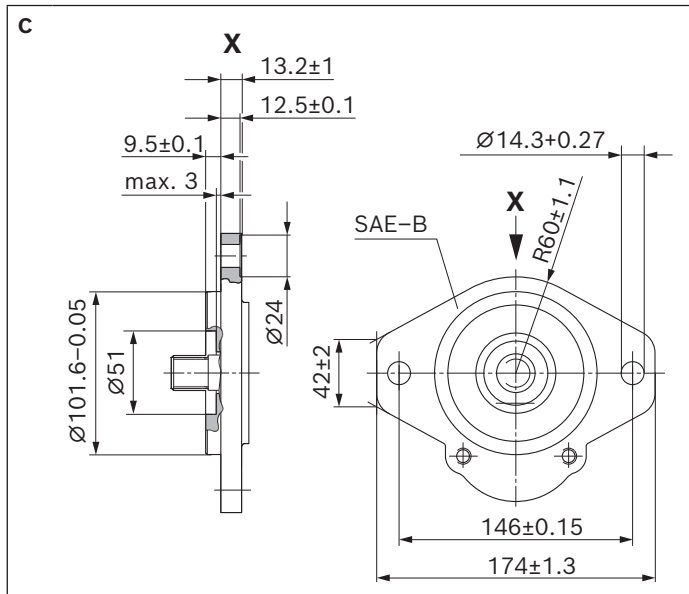

▼ 2-bolt mounting spigot dia. 52 mm, with O-ring

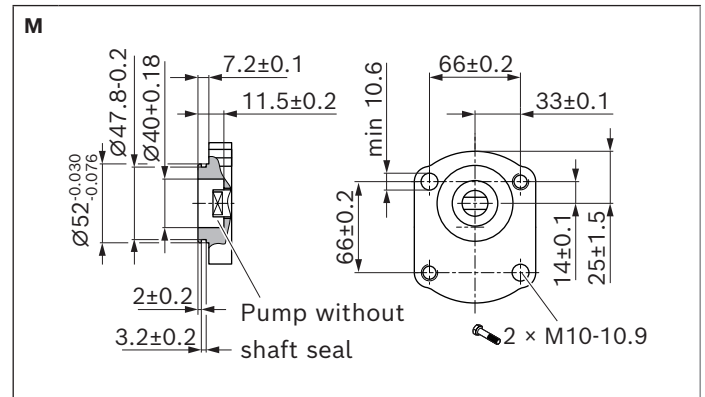

Port connections¹⁾

▼ SAE flange connection acc. to ISO 6162-1 with metric thread

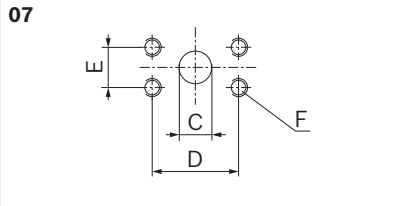

Nominal size	Series	Pressure side				Suction side			
		C mm	D mm	E mm	F	C mm	D mm	E mm	F
20	1x/2x	18	47.6	22.2	M10; 14 mm deep	25	47.6	22.2	M10; 14 mm deep
22 ... 36						25	52.4	26.2	

▼ SAE flange connection acc. to ISO 6162-1 with UNC thread

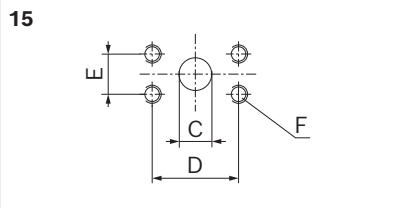

Nominal size	Series	Pressure side				Suction side			
		C mm	D mm	E mm	F	C mm	D mm	E mm	F
20 ... 36	1x/2x	19	47.6	22.2	3/8-16 UNC-2B; 14 mm deep	25	52.4	26.2	3/8-16 UNC-2B; 14 mm deep

▼ Square flange (German version)

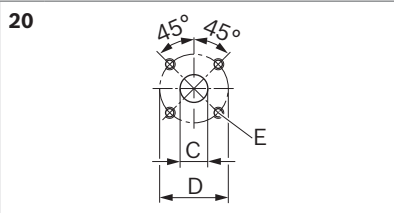

Nominal size	Series	Pressure side			Suction side		
		C mm	D mm	E	C mm	D mm	E
20 ... 36	1x/2x	18	55	M8; 13 mm deep	26	55	M8; 13 mm deep

▼ UN-thread acc. to ISO 11926-1/ASME B 1.1, O-ring²⁾

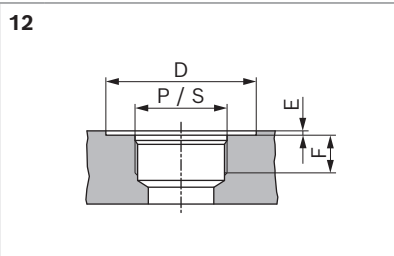

Nominal size	Series	Pressure side				Suction side			
		P	D	E	F	S	D	E	F
			mm	mm	mm		mm	mm	mm
20 ... 22	1x	7/8-14 UN-2B	35	0.5	17	1 5/16-12 UN-2B	50	0.5	20
25 ... 36		1 1/16-12 UN-2B	45						
20 ... 22	2x	7/8-14 UN-2B	35	0.5	17	1 5/16-12 UN-2B	50	0.5	20
25 ... 36		1 1/16-12 UN-2B	45						

1) Valid for series 1x and 2x

2) Limited service life with threaded ports (applicable for applications with $p_2 > 210$ bar)

Splined shaft SAE J744 22-4 13T with 2-bolt flange SAE J744 101-2 (B) spigot dia. 101.6 mm
AZPN-12- ... DC12MB

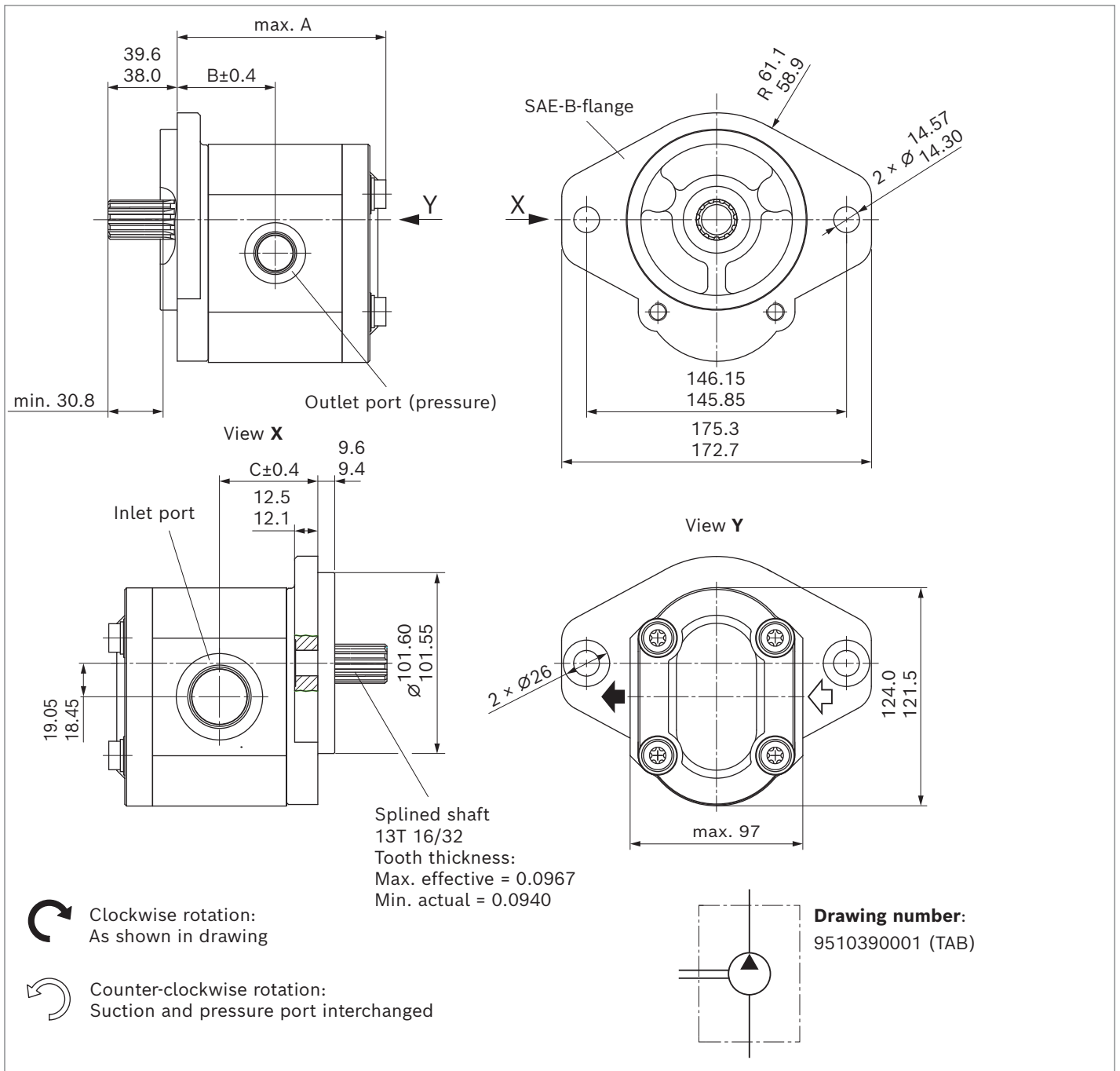

NG	Material number		Max. intermittent pressure ¹⁾ p ₂	Max. rotational speed n _{max}	Dimensions			Inlet port	Outlet port (pressure)
	Direction of rotation counter-clockwise	clockwise			A	B	C		
			bar	rpm	mm	mm	mm		
20	9510390007	9510390001	250	3000	109.8	52.1	52.1	SAE O-ring BOSS	SAE O-ring BOSS
22	9510390008	9510390002	250	3000	114.7	53.6	53.6	1 5/16-12 UN-2B THD	7/8-14 UNF-2B THD
25	9510390009	9510390003	250	3000	115.8	55.1	55.1		
28	9510390010	9510390004	230	2800	118.8	56.6	56.6	SAE O-ring BOSS	SAE O-ring BOSS
32	9510390011	9510390005	200	2800	123.3	58.8	58.8	1 5/8-12 UN-2B THD	1 1/16-12 UN-2B THD
36	9510390012	9510390006	180	2800	129.7	61.1	61.1		

1) Limited service life with threaded ports (applicable for applications with p₂ > 210 bar)

Splined shaft SAE J744 22-4 13T with 2-bolt flange SAE J744 101-2 (B) spigot dia. 101.6

AZPN-12- ... DC12MA

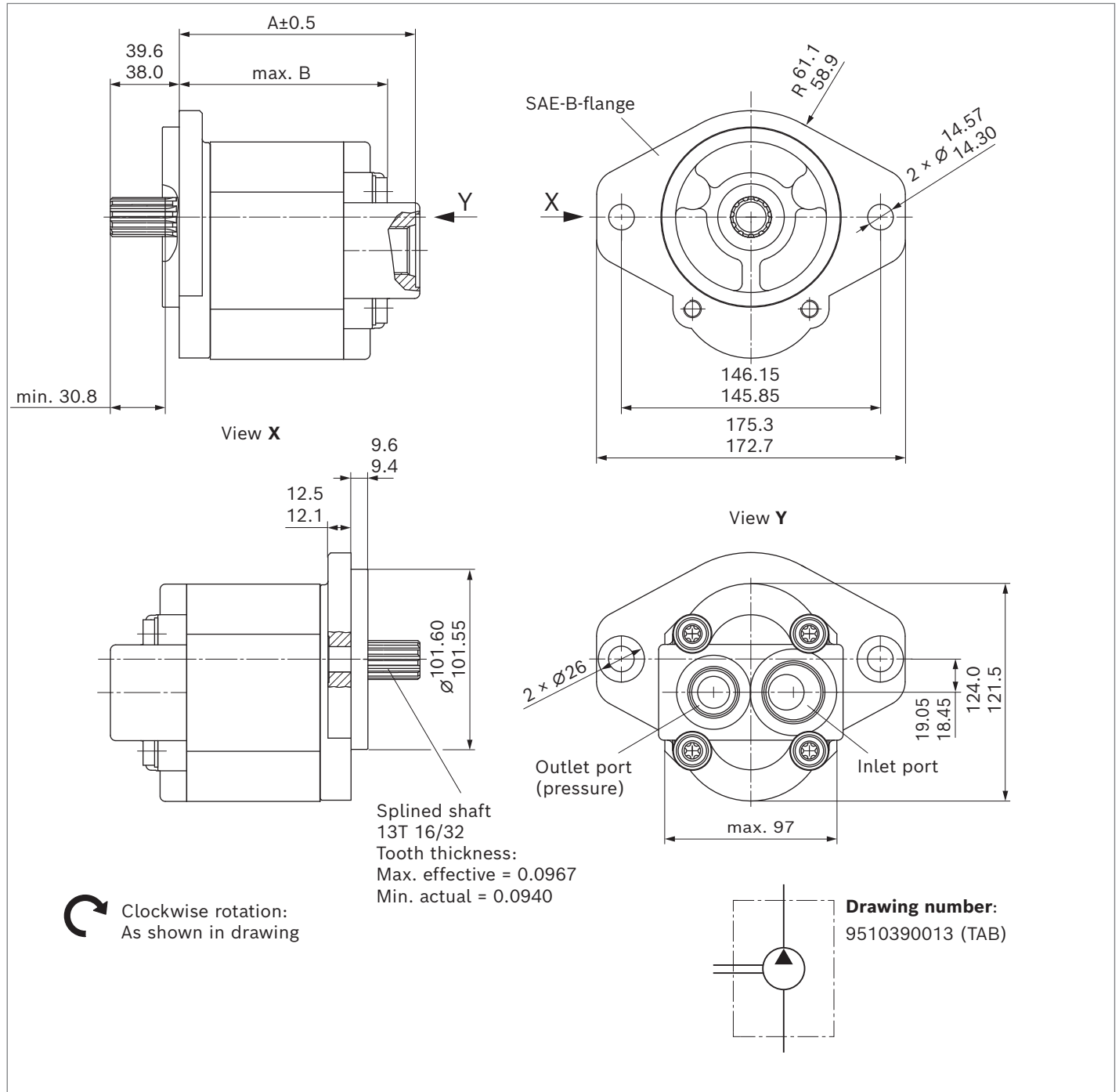

NG	Material number	Max. intermittent pressure ¹⁾ p_2	Max. rotational speed n_{max}	Dimensions		Inlet port	Outlet port (pressure)
				A	B		
	Direction of rotation clockwise	bar	rpm	mm	mm		
20	9510390013	250	3000	128.1	110.0		
22	9510390014	250	3000	131.1	114.9		
25	9510390015	250	3000	134.1	116.0	SAE O-ring BOSS	SAE O-ring BOSS
28	9510390016	230	2800	137.1	119.0	1 5/16 – 12-UN-2B THD	1 1/16 – 12-UN-2B THD
32	9510390017	200	2800	141.6	123.5		
36	9510390018	180	2800	146.1	129.9		

1) Limited service life with threaded ports (applicable for applications with $p_2 > 210$ bar)

Splined shaft SAE J744 16-4 9T with 2-bolt flange SAE J744 82-2 (A) spigot dia. 82.55 mm

AZPN-12- ... RR12MB

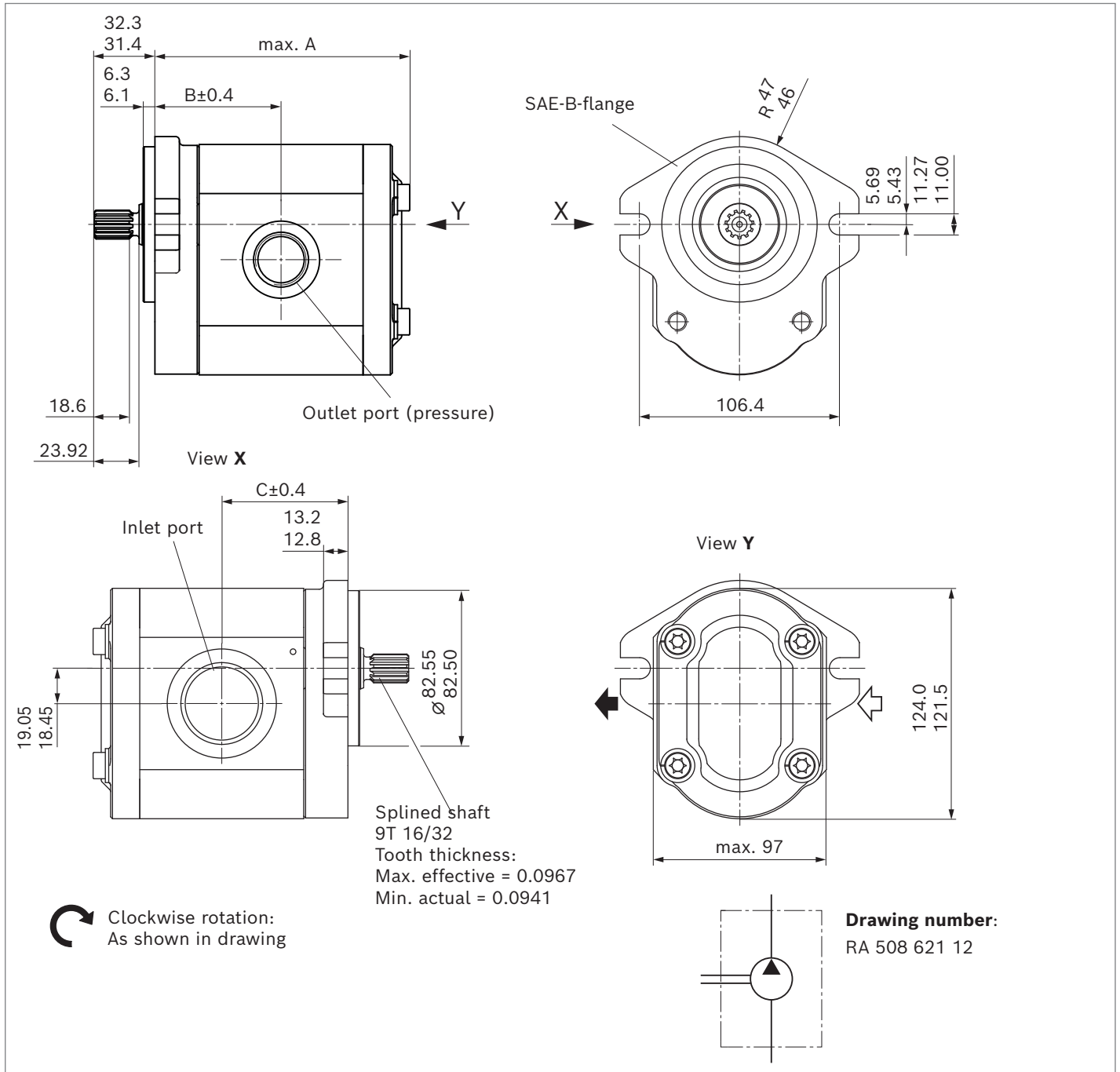

NG	Material number	Max. intermittent pressure ¹⁾ p_2	Max. rotational speed n_{max}	Dimensions			Inlet port	Outlet port (pressure)
				A	B	C		
	Direction of rotation clockwise	bar	rpm	mm	mm	mm		
20	9510390025	250	3000	115.8	58.1	58.1	O-ring BOSS- <small>SAE J1926/1</small>	O-ring BOSS- <small>SAE J1926/1</small>
22	9510390026	250	3000	120.7	59.6	59.6	1 5/16-12 UN-2B; deep 19	7/8-14 UNF-2B; deep 16.7
25	9510390027	250	3000	121.8	61.1	61.1	Torque 285±28 Nm Torque 103±10 Nm	
28	9510390028	230	2800	124.8	62.6	62.6	O-ring BOSS- <small>SAE J1926/1</small>	O-ring BOSS- <small>SAE J1926/1</small>
32	9510390029	200	2800	129.3	64.8	64.8	1 5/8-12 UN-2B; deep 19	1 1/16-12 UN-2B; deep 19
36	9510390030	180	2800	135.7	67.1	67.1	Torque 332±33 Nm Torque 176±17 Nm	

1) Limited service life with threaded ports (applicable for applications with $p_2 > 210$ bar)

Parallel keyed shaft SAE J744 16-1 (short version) with 2-bolt flange SAE J744 101-2 (B) spigot dia. 101.6 mm AZPN-12- ... QC12MB

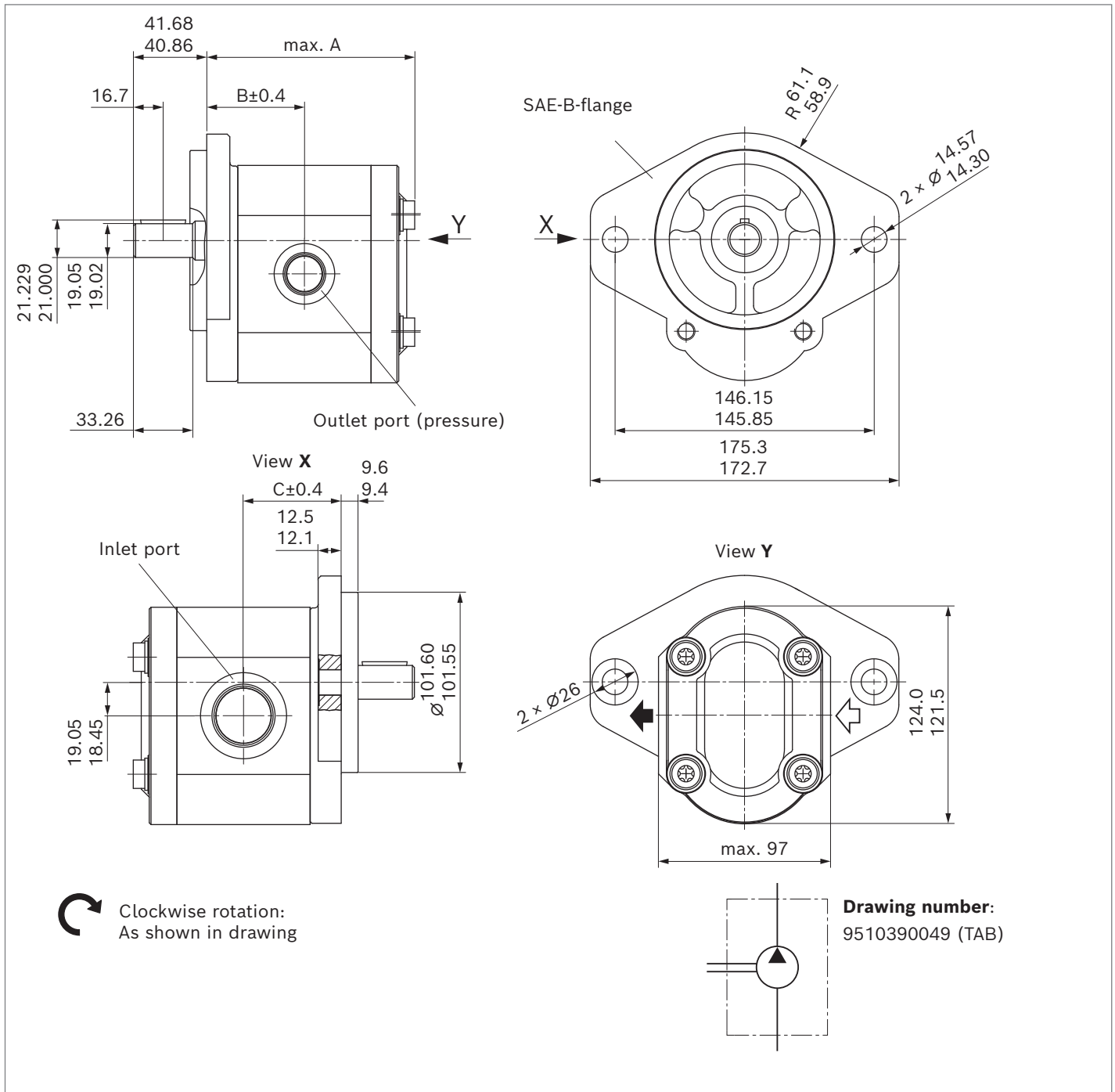

NG	Material number	Max. intermittent pressure ¹⁾ p ₂	Max. rotational speed n _{max}	Dimensions			Inlet port	Outlet port (pressure)
	Direction of rotation clockwise			A	B	C		
		bar	rpm	mm	mm	mm		
20	9510390049	250	3000	109.8	52.1	52.1	SAE O-ring BOSS	SAE O-ring BOSS
22	9510390050	250	3000	114.7	53.6	53.6	1 5/16 – 12 UN-2B THD	7/8 – 14 UNF-2B THD
25	9510390051	250	3000	115.8	55.1	55.1		
28	9510390052	230	2800	118.8	56.6	56.6	SAE O-ring BOSS	SAE O-ring BOSS
32	9510390053	200	2800	123.3	58.8	58.8	1 5/8 – 12 UN-2B THD	1 1/16 – 12 UN-2B THD
36	9510390054	180	2800	129.7	61.1	61.1		

¹⁾ Limited service life with threaded ports (applicable for applications with p₂ > 210 bar)

Splined shaft SAE J744 22-4 13T with 2-bolt flange SAE J744 101-2 (B) spigot dia. 101.6 mm

AZPN-1X- ... DC20MB / AZPN-1X- ... DC20KB

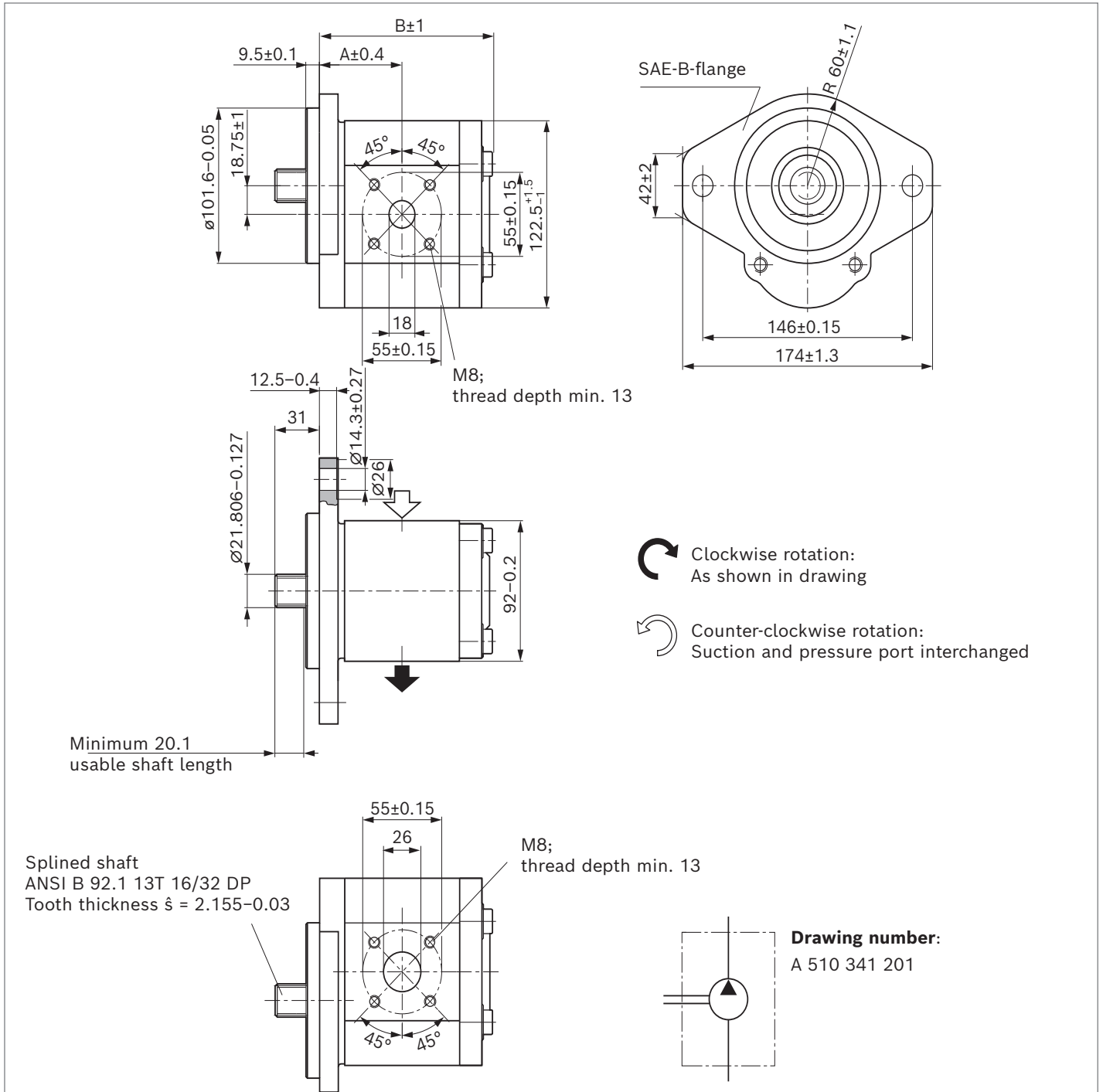

NG	Material number		Maximum intermittent pressure p_2 bar	Maximum speed n_{max} rpm	Weight m kg	Dimensions	
	Direction of rotation counter-clockwise	clockwise				A mm	B mm
20			250	2500		52.0	110.1
22			250	2500		53.5	112.6
25	0 510 725 377	0 510 725 057	250	2500	5.5	55.0	115.3
25		0 510 725 094	250	2500	5.5	55.0	115.3
28	0 510 725 431	0 510 725 058	230	2500	5.7	56.5	118.3
36	0 510 725 363	0 510 725 155	180	2500	6.0	61.0	123.3

Splined shaft SAE J744 22-4 13T with 2-bolt flange SAE J744 101-2 (B) spigot dia. 101.6 mm

AZPNN-11- ... **DC0707KB** S0081

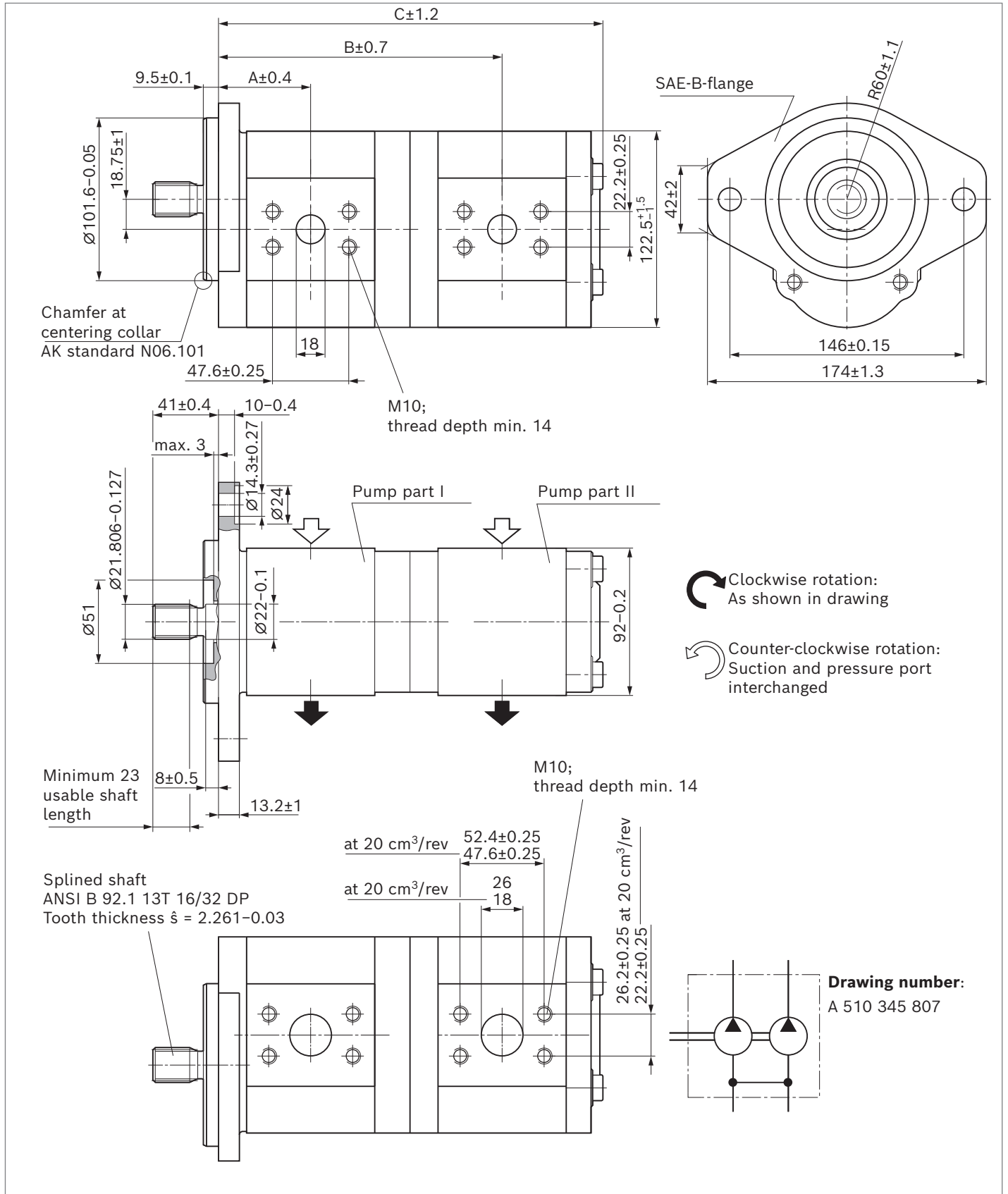

NG	Material number		Maximum intermittent pressure		Maximum rotational speed	Weight	Dimensions				
	P _I	P _{II}	Direction of rotation counter-clockwise	clockwise	p _{2 I} bar	p _{2 II} bar	n _{max} rpm	m kg	A mm	B mm	C mm
20	20	0 510 665 461	0 510 665 149		250	250	2000	9.9	52.0	160.7	217.9
22	20	0 510 765 369			250	250	2000	10.0	53.5	163.6	222.7
22	22	0 510 765 380	0 510 765 086		250	230	3000	10.1	53.5	165.2	225.7
25	20		0 510 765 067		250	250	2000	10.1	55.0	166.6	225.7
25	22		0 510 765 068		250	230	3000	10.2	55.0	168.2	228.7
25	25	0 510 766 315	0 510 765 069		250	200	3000	10.3	55.0	169.7	229.9
32	32	0 510 765 370	0 510 768 034		200	160	2500	10.9	29.0	181.2	244.9

NG	Material number		Maximum intermittent pressure		Maximum rotational speed	Weight	Dimensions				
	P _I	P _{II}	Direction of rotation counter-clockwise	clockwise	p _{2 I} bar	p _{2 II} bar	n _{max} rpm	m kg	A mm	B mm	C mm
20	4		0 510 665 181		250	280	3000		52.0	141.5	184.2
22	8	0 510 765 387	0 510 765 078		250	280	3000	8.4	53.5	147.9	193.8
22	11	0 510 765 381	0 510 765 062		250	280	3000	8.5	53.5	151.7	200.6
25	4	0 510 766 316			250	280	3000		55.0	147.6	190.2
25	11	0 510 765 377	0 510 765 079		250	280	3000	8.6	55.0	154.7	203.6
25	14		0 510 766 014		250	250	3000	8.7	55.0	155.2	206.8
25	16		0 510 765 080		250	230	3000	8.8	55.0	155.2	210.2
28	11		0 510 765 092		230	280	2800	8.7	56.5	157.7	206.6
28	16	0 510 765 384	0 510 765 063		230	230	2800	8.9	56.5	158.2	213.2
28	19	0 510 766 314	0 510 767 058		200	200	2800	9.0	56.5	158.2	219.8
28	22		0 510 767 045		230	200	2100	9.2	56.5	165.8	223.6
28	22	0 510 767 332			230	150	2100	9.3	56.5	165.8	223.6
32	8		0 510 765 064		200	280	2500	8.8	59.0	158.4	204.3
32	11	0 510 768 320	0 510 765 065		200	280	2500	8.9	59.0	162.2	211.1
32	14	0 510 765 378			200	250	2500	9.0	59.0	162.7	216.1
32	16		0 510 765 066		200	230	2500	9.1	59.0	162.7	217.7
32	22	0 510 768 318			200	150	2100		59.0	170.3	229.9

Project planning information

Technical data

All mentioned technical data are dependent on manufacturing tolerances and are applicable for certain boundary conditions.

Note that certain deviations are therefore possible and that technical data may vary when certain boundary conditions (e.g., viscosity) change.

Pumps delivered by Bosch Rexroth are tested for function and performance.

The pump may only be operated with the permissible data (see chapter “Technical data”).

Characteristic curves

When dimensioning the gear pump, observe the maximum possible application data on the basis of the characteristic curves shown.

Application information

External gear units are not approved in on-highway vehicles for safety-relevant functions, as well as functions in the drive train, for steering, braking and level regulation. Classified as on-highway vehicles are e.g. vehicles such as motorbikes, private cars, trucks, vans, freight cars, buses and trailers. The European vehicle classes L (motorbikes), M (private cars), N (vehicles for transporting goods such as trucks and vans) and O (trailers and semi-trailers) serve as reference.

Notice

When used as an auxiliary steering pump, the vehicle manufacturer should make sure that the steering system continues to operate safely, even if the auxiliary steering pump fails (regulation similar to ECE R-79 can be referred).

Filtration of the hydraulic fluid

Since the majority of premature failures in gear pumps occur due to contaminated hydraulic fluid, filtration should maintain a cleanliness level of 20/18/15 as defined by ISO 4406. Thus contamination can be reduced to an acceptable degree in terms of particle size and concentration. Bosch Rexroth generally recommends full-flow filtration.

The basic contamination of the hydraulic fluid filled in should not exceed class 20/18/15 as defined by ISO 4406. New fluids are often above this value. In such instances, a filling device with a special filter should be used.

Bosch Rexroth is not liable for wear due to contamination. For hydraulic systems or devices with function-related, critical failure effects, such as steering and brake valves, the type of filtration selected must be adapted to the sensitivity of these devices.

Further information

Installation drawings and dimensions are valid at date of publication, subject to modifications.

Further information and notes on project planning can be found in the “General Operating Instructions for External Gear Units” (07012-B, chapter 5.5).

Information

AZ configurator

With our practical product selector, it will take you next to no time to find the right solution for your applications, no matter whether it is SILENCE PLUS or another external gear unit.

The selector guides you through a selection of features to all of the products available for order. By clicking on the order number, you can view and download the following product information: Data sheet, dimension sheet, operating conditions, and tightening torques.

You can order your selection directly via our online shop and at the same time benefit from an additional discount of 2%. And if you need something really quickly, simply use our fast delivery and preferred programs (GoTo). Then the goods will be sent within 10 working days.

You also have the possibility to easily and conveniently configure your individual external gear unit with our AZ configurator. All the necessary data that you need for the project planning of external gear units is requested by means of the menu navigation.

For an already existing configuration you receive as a result the order number, the type code, as well as further information. If your configuration does not lead to a product that is available for order, our online tools provide you with the possibility of sending a project request directly to Bosch Rexroth. We will then get in contact with you.

Link: www.boschrexroth.com/az-configurator

Spare parts

Spare parts can be found online at

www.boschrexroth.com/spc

Select “Spare parts and accessories” and enter the material number of the external gear units into the search field.

Example:

Material number: **0 510 625 335**

Type designation: AZPN-11-020LCB20MB

All available spare parts are listed under “Spare parts” and can be ordered via the shopping basket.

Pos.	Material number	Designation	Quantity	Launch / Discontinuation
1		PUMP HOUSING	1	
2		BEARING COVER	1	
3	1510283023	ROTARY SHAFT LIP SEAL ROTARY SHAFT LIP 40X22X7-SL-NBR-77	1	
4	2016880018	RETAINING RING	1	

Further information

Extensive notes and suggestions can be found in the Hydraulic Trainer, volume 3: “Planning and Design of Hydraulic Power Systems”, order number R900018547.

Accessories

90° angle flange, for square flange (German version) 20

Complete screw connections with O-ring, metric screw set, nuts and olive.

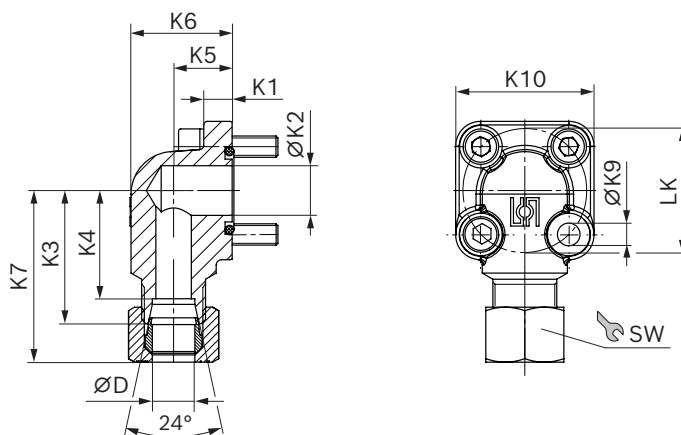

LK	D	Series ¹⁾	Material number	p_{max}	K1	K2	K3	K4	K5	K6	K7	K9	K10	SW	Screws		O-ring	Weight
mm	mm			bar	mm	mm	mm	mm	mm	mm	mm	mm	mm	mm	2 ×	2 ×	NBR	kg
55	20	S	1 515 702 004	250	13	18.2	45	34.5	24	38	57.0	8.4	58	36	M8 × 25	M8 × 50	32 × 2.5	0.62
55	30	S	1 545 719 006	250	12	26.5	49	38.5	32	51	63.5	8.4	58	50	M8 × 25	M8 × 50	32 × 2.5	0.63
55	35	L	1 515 702 005	100	12	26.5	49	38.5	32	52	61.0	8.4	58	50	M8 × 25	M8 × 60	32 × 2.5	0.77
55	42	L	1 515 702 019	100	12	26.5	49	38.0	40	64	61.5	8.4	58	60	M8 × 25	M8 × 70	32 × 2.5	1.04

Notice

Permissible tightening torques can be found in the “General instruction manual for external gear units”:

www.boschrexroth.com/07012-B

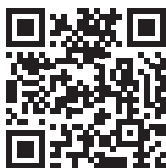

1) See DIN EN ISO 8434-1

Bosch Rexroth AG

Robert-Bosch-Straße 2
71701 Schwieberdingen
Germany
brm-az.info@boschrexroth.de
www.boschrexroth.com

© Bosch Rexroth AG 1998. All rights reserved, also regarding any disposal, exploitation, reproduction, editing, distribution, as well as in the event of applications for industrial property rights. The data specified within only serves to describe the product. No statements concerning a certain condition or suitability for a certain application can be derived from our information. The information given does not release the user from the obligation of own judgment and verification. It must be remembered that our products are subject to a natural process of wear and aging.